



# Worksheet (1)

---

- Write regular expressions that generate the following:
  1. Binary numbers (strings over the alphabet  $\{0,1\}$ ) with no leading 0's.
    - Answer:  $1.(0|1)^*$
  2. Strings over the alphabet  $\{a,b,c\}$  where the **length** of the string is even.
    - Answer:  $((a|b|c).(a|b|c))^*$
  3. Strings over the alphabet  $\{a,b,c\}$  where the first **a** **precedes** the first **b**.
    - Answer:  $(a|c)^*.(a.b.(a|b|c)^*)|\epsilon$
  4. Strings over the alphabet  $\{a,b,c\}$  that **don't** contain the substring **baa**.
    - Answer:  $a^*(b|ba|ca^*)^*$

# Worksheet (2)

- Describe the strings which the following automata accept:

1:

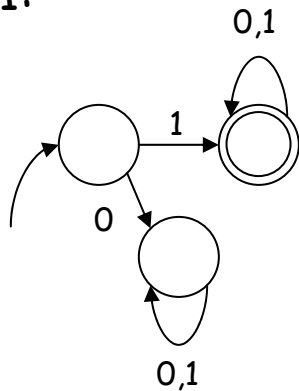

Answer:

Binary numbers (strings over the alphabet  $\{0,1\}$ ) with **no** leading 0's.

# Worksheet (2)

- Describe the strings which the following automata accept:

2:

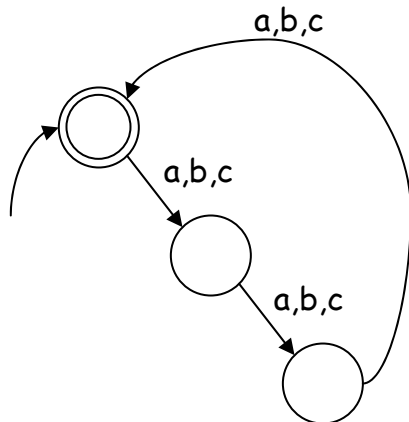

Answer:

Strings over the alphabet  $\{a,b,c\}$  whose length is a multiple of 3.

# Worksheet (2)

- Describe the strings which the following automata accept:

3:

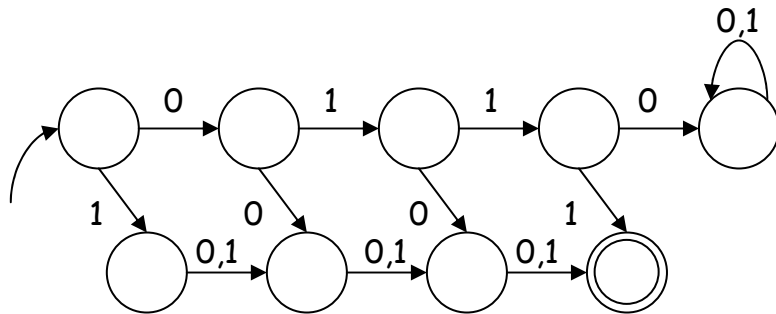

Answer:

All 4-bit binary numbers with the exception of 0110.

Or all binary-encoded numbers between 0 and 63 except for 6.

# Worksheet (3)

- Convert the following regular expressions to NFAs:
  - $(a|b).c$

Answer:

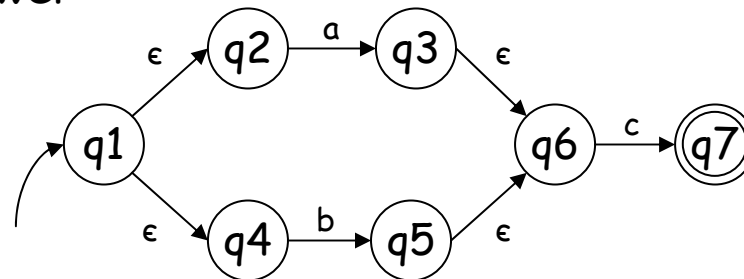

# Worksheet (3)

- Convert the following regular expressions to NFAs:
  - $a.(b|c)^*$

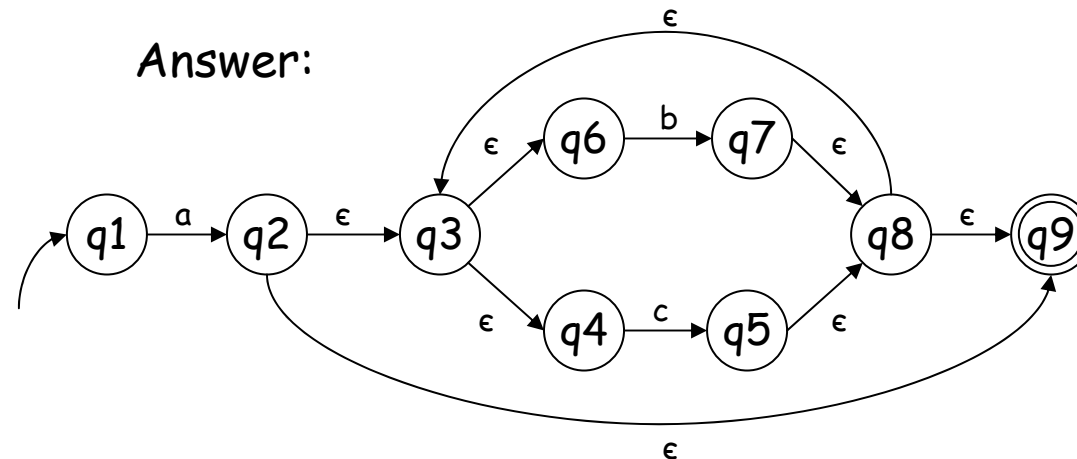

# Worksheet (3)

- Convert the following NFAs to DFAs:

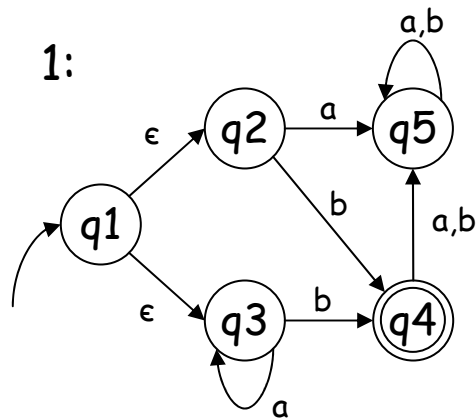

Answer:

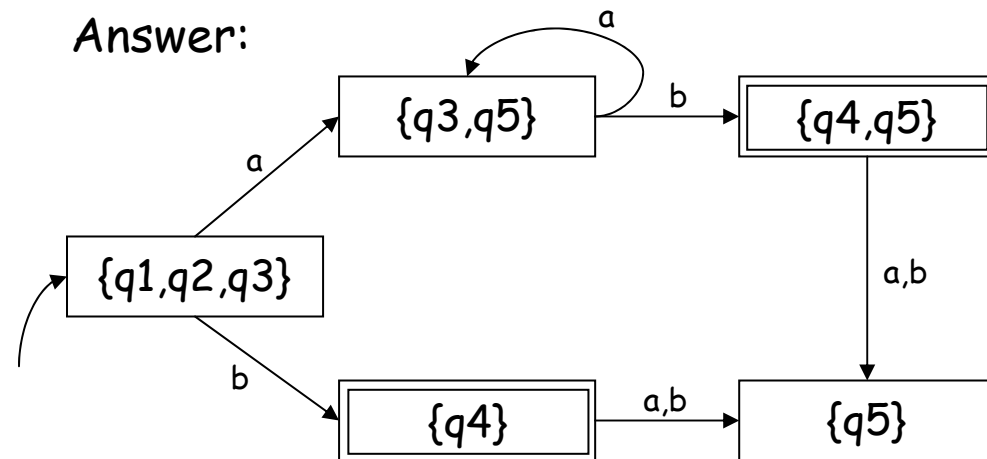

# Worksheet (3)

- Convert the following NFAs to DFAs:

